

VAPI GREEN ENVIRO LIMITED

Plot No.135, VIA House, GIDC Char Rasta, Vapi 396 195

Tel.: 91 260 2428950 , 9714000828

E Mail: dgm.purchase@vgelvapi.com

CIN: **U74210GJ1997GAP031525**

To engage Consultant

Vapi Green Enviro Limited (VGEL) invites Proposal from reputed consultants for Design and Detail Engineering in areas of Process, Mechanical, Piping, Civil, Electrical, Instrumentation etc. for the expansion of CETP from 55 to 70 MLD (Additional 15 MLD) as per design prepared by IIT – Bombay.

During execution, the consultant should monitor the progress on regular basis and ensure the quality of work and equipments are as per tender specifications. The consultant will complete all commissioning and ensure the working of Civil, Electrical, Mechanical, Piping, Instrumentation as per the specifications / Design.

Index

1. **Section 1**: Important Dates and Information of the Tender
2. **Section 2**: General Instructions
3. **Section 3**: Qualification & Technical Criteria
4. **Section 4**: Financial Condition
5. **Section5**: Price Bid

Interested parties may forward their detailed profile to: -

Chief Executive Officer,
Vapi Green Enviro Limited,
Plot No.135, VIA House,
GIDC, Vapi 396 195. Tel: 0260 2428950, 2429950

VAPI GREEN ENVIRO LIMITED

Plot No.135, VIA House, GIDC Char Rasta, Vapi 396 195
Tel.: 91 260 2428950 , 9714000828
E Mail: dgm.purchase@vgelvapi.com
CIN: U74210GJ1997GAP031525

Section 1: Important Dates and Information of the Tender

Title of the tender: Vapi Green Enviro Limited (VGEL) invites Proposal from reputed consultants for Design and Detail Engineering in areas of Process, Mechanical, Piping, Civil, Electrical, Instrumentation etc. for the expansion of CETP from 55 to 70 MLD (Additional 15 MLD) as per design prepared by IIT – Bombay.

During execution, the consultant should monitor the progress on regular basis and ensure the quality of work and equipments are as per tender specifications. The consultant will complete all commissioning and ensure the working of Civil, Electrical, Mechanical, Piping, Instrumentation as per the specifications / Design.

Tender Number : VGEL/CETP/002 – Date: 14-10-2024

Pre-Bid meeting on : 14:00 Hrs on Date: 21/10/2024 at CETP Site, Vapi.

Mode of Submission : Speed Post/Register Post/Courier/Hand Delivery.

Last date of submission : 12:30 PM on Date: 28-10-2024 at Head Office Address.

Opening Bid date on : 13:00 PM on Date: 28-10-2024 at Head Office Address.
(Possibly Bid opening depends on availability of signing authority)

Validity of Bid : Minimum 120 Days.

Tender Fee : Rs.2,400/-+18% GST = Rs.2,832/- (Non-refundable)

EMD : Rs.1,00,000/- (Refundable)

Completion of Project : 3 Months from the date of Work Order.

Important Note : **Envelop should be superscripted as below.**

“To engage Consultant for development of 15 MLD Expansion at CETP Vapi, Tender Number: VGEL/CETP/002 – Date: 14-10-2024.

VAPI GREEN ENVIRO LIMITED

Plot No.135, VIA House, GIDC Char Rasta, Vapi 396 195

Tel.: 91 260 2428950 , 9714000828

E Mail: dgm.purchase@vgelvapi.com

CIN: U74210GJ1997GAP031525

Section 2: General Instructions

- 1) Interested parties may obtain the tender document from the website www.vgelvapi.com.
- 2) The duly filled Tender Document is to be sent to below address before last submission Date:

The Chief Executive Officer,
Vapi Green Enviro Limited.
135, VIA House, Char Rasta
GIDC, Vapi 396 195
Gujarat (India)
- 3) The bids should be submitted in a sealed cover containing following two separate envelopes:
(a) Technical Bid:
 1. Technical qualification page along with all the documents mentioned in it.
 2. Copy of all sections except section 5 i.e. Price Bid duly signed & stamped on all the pages.
 3. Section: 3 having Financial Condition also to be signed and submitted with Technical Bid.
 4. No condition other than what already mentioned in the tender documents will be accepted.
(b) Price Bid:
 1. To be submitted in Separate Sealed Envelope with name of Tender, Name of Supplier and Receiver.
- 4) The bid shall be submitted in Sealed Condition within last submission date through speed post / register post / courier or hand delivery. The complete liability to ensure that the Signed bid shall reach in time will be with the bidder. Under no circumstance will allow any allowance for the delay arising out of postal or courier delivery.
- 5) VGEL reserves the right to accept or reject any or all tenders in part or full or to cancel the issue of tender documents without assigning any reason whatsoever. Similarly, in the interest of company, company have absolute right to go for retendering without assigning any reason whatsoever to anyone.
- 6) Bidder has to accept all terms and conditions unconditionally.
- 7) Management reserves the right to modify the tender document for more clarity and/or to get more competition. If there is any revision in the tender document, the same will be published on our website www.vgelvapi.com. All the interested parties are requested to regularly check our website for any updates.
- 8) Negotiations, if any, for any item will be held with the respective L1 party. No bidder will have any right whatsoever for his bid if it is not obtained in time and in proper format.
- 9) NEWS Paper Advertisement published in NEWS Paper. Kindly note that all tender document and Corrigendum are posted on our website www.vgelvapi.com.

VAPI GREEN ENVIRO LIMITED

Plot No.135, VIA House, GIDC Char Rasta, Vapi 396 195

Tel.: 91 260 2428950 , 9714000828

E Mail: dgm.purchase@vgelvapi.com

CIN: **U74210GJ1997GAP031525**

- 10) Interested parties may obtain the tender document from the website www.vgelvapi.com , Site of VGEL as mentioned in Section 1.
- 11) The duly filled Tender Document is to be sent to Head Office Address and Equipment to be installed at Centre of Excellence Address.

Head Office Address	CETP Site Address
The Chief Executive Officer, Vapi Green Enviro Ltd. 135, VIA House, Char Rasta GIDC, Vapi 396 195, Gujarat (India)	Common Effluent Treatment Plant, S. NO. 901/ to 906/P, Near Damanganga River, Phase 1, GIDC Industrial Estate, Vapi-396195, Dist. Valsad

- 12) The completed tender forms will be received at Head office Address during office hours i.e. 10:00 AM to 5:00 PM up to the last date mentioned in Section1.

VAPI GREEN ENVIRO LIMITED

Plot No.135, VIA House, GIDC Char Rasta, Vapi 396 195

Tel.: 91 260 2428950 , 9714000828

E Mail: dgm.purchase@vgelvapi.com

CIN: U74210GJ1997GAP031525

Section 3: Qualification & Technical Criteria

Qualification Criteria: -

Sr. NO.	Description	To be confirmed by supplier YES / NO
1	The bidder should have done design and detail engineering for similar type CETP for 15 MLD or more of Heterogeneous Chemical Waste Water treatment coming from Dyes, Pharma, Pesticide, Paper recyclers, Textiles etc.	
2	Over the past 5 years the Consultant should have executed handled as well as conversant and aware of projects of similar type and be able to demonstrate any 2 of recently completed successfully operating projects for government and/or semi-government and/or private reputed organizations anywhere in India. At least One Project completed within Gujarat. Copy of order / certificate for work completion to be attached.	
3	Consultant should be very well conversed with CPCB, MOEF, CPHEEO Guidelines and design criterion and having knowledge of statutory standards (PCB, Fire & Emergency services). Consultant should have excellent knowledge of construction safety standards and EHS guidelines and be familiar with NBC Standards.	
4	<i>Consultant should be well-versed with latest technology including Advanced Aeration System, De-Watering system/Sludge handling System, Instrument and SCADA system, Automation Etc.</i>	
5	Consultant should develop the infrastructure based on Design submitted from IIT Bombay	
6	The consultancy firm should have followed Technical Experts: 1. Team Leader or Project Coordinator [1no] : Masters M. Tech and/or B.E./B.Tech. in Civil with Environment / Chemical as major, having min. 10-12 years' experience in the field of Environment, Design, consultation, Supervision, construction, operation and maintenance of CETP along with its auxiliary utilities. 2. Structural Design Engineer [1no] : Masters or B.E./B.Tech in Civil Structural/Architect having Designing experience of min. 8-10 year. 3. Site Engineer [1no] : Degree / Diploma in Civil / Mechanical / Electrical & Instrumentation. He should have min. 3 years' experience in site supervision of site. a. Civil Engineer during civil construction b. Mechanical Engineer during mechanical Installation c. Electrical & Instrumentation during Electrical & Instrumentation	
7	Establishment of consultancy Firm : At least 5-year-old Registration firm having experience of CETP site related infrastructure facilities designing.	

VAPI GREEN ENVIRO LIMITED

Plot No.135, VIA House, GIDC Char Rasta, Vapi 396 195

Tel.: 91 260 2428950 , 9714000828

E Mail: dgm.purchase@vgelvapi.com

CIN: U74210GJ1997GAP031525

8	<i>PTR (Performance Track Record) required to submit with this tender.</i>	
9	Acceptance of all the conditions fully and unconditionally : Copy of all the pages of Tender to be submitted with signed and stamped on all the pages.	
10	Submission of EMD amount as per section:1 (Refundable): DD or Banker's Cheque of amount mentioned in Section 1, in favour of Vapi Green Enviro Ltd.	Amt. Rs. _____ DD or Banker's Cheque No.: _____
11	Submission of Tender Fee amount as per section:1 (Non-refundable): DD or Banker's Cheque of amount mentioned in Section 1, in favour of Vapi Green Enviro Ltd.	Amt. Rs. _____ DD or Banker's Cheque No.: _____

Technical Details:

Scope of Work for project Consultant for 15 MLD CETP expansion:

A. CETP expansion from 55 to 70 MLD (15 MLD) as per IIT-B Suggestions:

- 1. Finalization of layout as per the scheme given by IIT-B, keeping in view of future expansion.*
- 2. Process calculations for air requirement, sizing of pipelines, sumps, selection of pumps, blowers, mixers, Instrumentation and other mechanical & civil equipments.*
- 3. Designing of the Guard Pond as per the requirement*

B. Detail Design and Preparation of drawings:

- 1. Civil and structural components*
- 2. Piping & Instrumentation*
- 3. Automation and SCADA system*
- 4. Electrical*
- 5. Mechanical*
- 6. Preparation of PFD, HFD, P&ID.*
- 7. Preparation of Technical DATA Sheet for all Equipment / Mechanical / Electrical / Instrumentation.*

C. Details of Cost:

- 1. Capital Cost*
- 2. Power requirement*
- 3. Chemical requirements*
- 4. Sludge generation and disposal*
- 5. Operating Cost*

D. Tendering:

- 1. Preparation of Tender with Specifications and BOQ*
- 2. Assisting VGEL during Tender Invitation and evaluation*

VAPI GREEN ENVIRO LIMITED

Plot No.135, VIA House, GIDC Char Rasta, Vapi 396 195

Tel.: 91 260 2428950 , 9714000828

E Mail: dgm.purchase@vgelvapi.com

CIN: **U74210GJ1997GAP031525**

3. *Assisting in appointment of contractor*

E. *Project Management:*

1. *During execution supervision/inspection of quality of material shall be carried out.*
2. *Inspect and evaluate whether work execute as per approved design/drawing and clarify for any discrepancy/ambiguity in drawing/specification*
3. *Continuous Supervision / inspection of the project till the project is completed.*
4. *Reporting the project progress with PERT charts. Site Meeting to be conducted every fortnight.*
5. *Preparation of DPR*
6. *Regular reporting*

Enclosure:

Proposed Process Flow diagram of CETP is attached at last page of this Tender document.

VAPI GREEN ENVIRO LIMITED

Plot No.135, VIA House, GIDC Char Rasta, Vapi 396 195

Tel.: 91 260 2428950 , 9714000828

E Mail: dgm.purchase@vgelvapi.com

CIN: U74210GJ1997GAP031525

Section 4: Financial Condition

1. **PRICE:** Price to be quoted by the bidder should be fixed and should cover the entire the scope of this work. The price quoted by the bidder to be inclusive of all taxes, levies, duties etc. as may be applicable or specifies clearly TAX details at section 5.

2. **FEES AND PAYMENT TERMS**

In consideration for the professional services performed by it in pursuance to scope of work specified in the bid document, <Successful Bidder> shall be entitled to receive from VGEL, professional fees on the following basis:

A. Professional Fees

The total cost to carry out the work as specified in Section 5 of this tender document. Please specify clearly that Service Tax is including or excluding in quoted price.

B. Fee Structure and Time Duration.

The fee for the assignment shall be released after acceptance and approved by Client as per stages mentioned as under in installments.

Stage	Stages % Fees entitled to be released	% of total Fees	Cumulative %	Time Duration	Deliverable
	Award of Contract	10%	10%	0 Month	
1	Submission and approval of Lay-Out and GA Drawing of the site.	05% On acceptance of report	15%	15 Days (0.5) (M+0.5)	As per Scope of Work
2	Submission and approval of HFD, PFD, and P&ID and process calculation, Technical DATA Sheet.	10% On acceptance of report	25%	15 Days M + 1	As per Scope of Work
3	Submission and approval of Civil and Structural design and working drawings of all Civil Work	10% On acceptance of report	35%	One month M+2	As per Scope of Work
4	Submission and approval of detailed BOQ, estimate, specifications, DPR (detailed Project report) and tender document for all the work	25% On acceptance of report	60%	One month M+3	As per Scope of Work
5	Evaluation of received Tender and finalization of contractor	10% on Acceptance of Report	70%	15 Days M+3.5	
6	Supervision / Inspection during execution of the work.	15% On acceptance of report	85%		
7	Successful Commissioning of 15 MLD Expansion	10% on Acceptance of Report	95%		
8	Retention Money to be released after 1 Year from the date of Successful Commissioning of 15 MLD Plant.	5%	100%		

VAPI GREEN ENVIRO LIMITED

Plot No.135, VIA House, GIDC Char Rasta, Vapi 396 195
Tel.: 91 260 2428950 , 9714000828
E Mail: dgm.purchase@vgelvapi.com
CIN: U74210GJ1997GAP031525

Section 5: Price Bid

No.	Description	Unit	Quotation in % of Project Cost
1	Consultancy Fees for the Project	%	
	Quotation to be submitted in % of Total Project Cost		

Note:

1. The bidder has to include all other charges (visiting / Supervision / Inspection), taxes, duties, transportation etc while quoting rates.
2. If Consultant will not specify in below table then it will be considered as included in basis price.

Mention details whichever is applicable	
GST	%
Other	%
Contact Person : Name:	
Mobile:	
Email :	

3. VGEL has full right to derive a formula to bring all the bidders to a common denominator so as to compare the offers.
4. The price is inclusive of all the technical support during the execution of work including the transportation charges of the personnel involved.
5. The offer is being made after reading and accepting all the conditions fully and unconditionally.

(Signature and Stamp of bidder)

VAPI GREEN ENVIRO LIMITED

Plot No.135, VIA House, GIDC Char Rasta, Vapi 396 195

Tel.: 91 260 2428950 , 9714000828

E Mail: dgm.purchase@vgelvapi.com

CIN: U74210GJ1997GAP031525

VENDOR REGISTRATION FORM

The Bidder who is **not registered** at Vapi Green Enviro Ltd. has to compulsory fill below form:

1	Supplier / Contractor / Both *	
2	Name *	
3	Type of Vendor * [Regd. Manufacturer / Non-Regd. Manufacturer / Regd. Distributer / Non-Regd. Distributer / Transporter / Retailer / Service Provider / Other]	
4	Branch [CETP, CSWP, COE, HO] *	
5	Address 1 *	
	Address 2	
	Address 3	
6	City *	
7	State *	
8	Country *	
9	Pin Code *	
10	Phone No.1 *	
11	Phone No.2 *	
12	Extension	
13	Mobile No. *	
14	Fax No.	
15	E-Mail ID. *	
16	PAN No.	
17	MSME Registration No.	
18	GST Registration No. **	
19	Name of the Bankers *	
20	Bank Branch *	
21	Bank Account No. *	
22	RTG/NEFT Ref. No. *	
23	Contact Person Name	
24	Designation	
25	Contact Person Mobile No.	
26	E-mail ID.	
27	Performance	
28	Remarks	

- a) ** Marked is mandatory entry for Contractor. Without this data, form will not be accepted by VGEL.
- b) If any details are not applicable / not available the please type "NA".
- c) Also, kindly mail the above Updated file to e-mail address "dgm.purchase@vgelvapi.com" & "se.purchase1@vgelvapi.com" in excel format.
- d) Please attach copy of GST, PAN, cancelled cheque & MSME/Udyam Registration (If available) along with this form.

SIGN AND STAMP OF THE BIDDER

Page 10 of 10

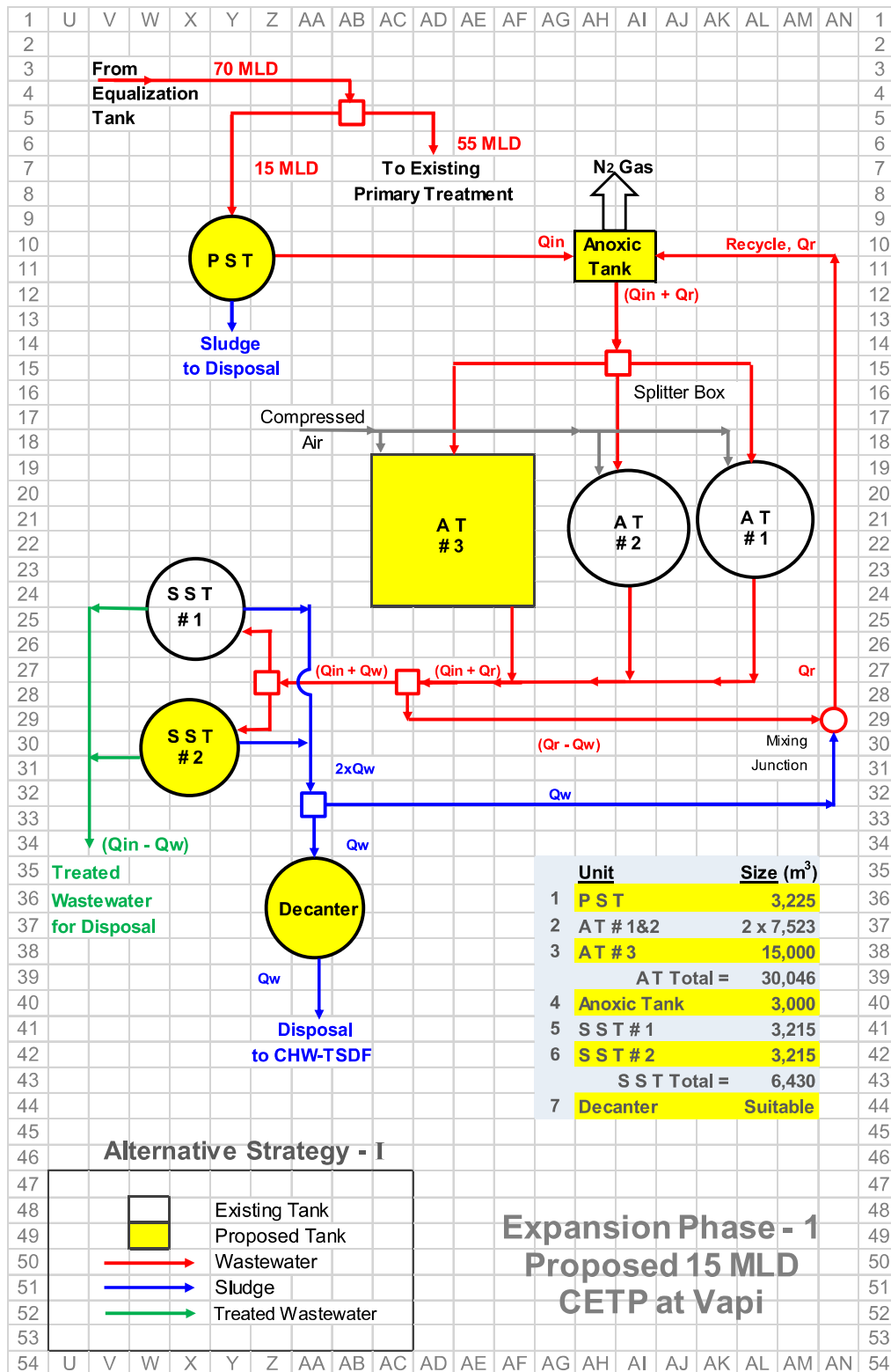

Figure 4.2: (Alternative Strategy - I) Process flow diagram of proposed 15 MLD for Expansion Phase -1 of CETP at Vapi. Here the conventional secondary settling tanks are used for solid-liquid separation.